

**Series 2, Built-in fridge-freezer with freezer at bottom, 177.2 x 54.1 cm, flat hinge
KIN85NFF0G**



Included accessories

3 x egg tray
1 x ice cube tray

The spacious built-in fridge-freezer combination with NoFrost provides optimal food storage and ice formation is no longer an issue.

- **MultiBox XXL:** extra-large drawer for your fruit and vegetables.
- **EcoAirflow:** optimal air circulation and a constant temperature level in the cooling area.
- LED lights bring a completely new lighting concept to fridges
- **SuperFreezing:** Protects frozen food from defrosting.
- FreshSense sensors constantly monitor and control the ambient, fridge and freezer temperature

Technical Data

Energy Efficiency Class: F

Average annual energy consumption in kilowatt hour per year (kWh/a): 298 kWh/a

Sum of volume of frozen compartments: 99 l

Sum of volume of chill compartments: 150 l

Airborne acoustical noise emissions : 39 dB(A) re 1 pW

Airborne acoustical noise emission class: C

Construction type: Built-in

Door panel options: Possible but accessory

Height: 1772 mm

Width of the appliance: 541 mm

Depth of the product: 548 mm

Min. required niche size for installation (HxWxD): 1775.0 x 560 x 550 mm

Net weight: 53.0 kg

Fuse protection: 10 A

Door hinge: Right reversible

Voltage: 220-240 V

Frequency: 50 Hz

Length of electrical supply cord: 230.0 cm

Number of compressors: 1

Number of independent cooling systems: 1

Interior ventilator: No

Reversible Door Hinge: Yes

Number of Adjustable Shelves in fridge compartment (Stck): 2

Shelves for Bottles: No

Frost free system: Freezer

Installation type: Full-integrated

Type of hinge: Flush-folding



4 242005 246878

Series 2, Built-in fridge-freezer with freezer at bottom, 177.2 x 54.1 cm, flat hinge KIN85NFF0G

The spacious built-in fridge-freezer combination with NoFrost provides optimal food storage and ice formation is no longer an issue.

- Built-in fridge-freezer combination
- Fixed hinge, softClosing door: No
- easy Installation

Functions

- Bright interior LED fridge light in fridge section

Design features

- LED electronic control
- Super Cooling: No
- Optical and accoustical

Design features

- 3 safety glass shelves in fridge compartment of which 2 are height adjustable
- 2 door trays, including 0x dairy compartment
- 1 removable door storage compartments.

Freshness System

- 1 MultiBox - Transparent drawer with a rippled bottom, ideal for storing fruits and vegetables.

Food freshness system

- SuperFreezing function with automatic deactivation

Dimension and installation

- Dimensions: 177.2 cm H x 54.1 cm W x 54.8 cm D
- Niche Dimensions: 177.5 cm H x 56 cm W x 55 cm D

Key features - Fridge section

- Right hinged door, door reversible
- 220 - 240 V

Key features - Freezer section

- 3 x egg tray, 1 x ice cube tray

Country Specific Options

- Based on the results of the standard 24-hour test. Actual consumption depends on usage/position of the appliance.
- NoFrost freezer, never have to defrost ever again
- 4 freezer drawers

Performance and Consumption

- Total Volume : 249 l
- EU19_EEK_D: F
- Net Fridge Volume : 150 l
- Net Freezer Volume : 99 l
- Freezing capacity 24h : 5.5 kg
- Annual Energy Consumption: 298 kWh/a
- Climate Class: SN-ST
- Noise Level : 39 dB , EU19_Noise emission class_D: C
- Temperature rise time : EU19_Temperature rise time_D: 10 H

Series 2, Built-in fridge-freezer with freezer at bottom, 177.2 x 54.1 cm, flat hinge KIN85NFF0G

measurements in mm

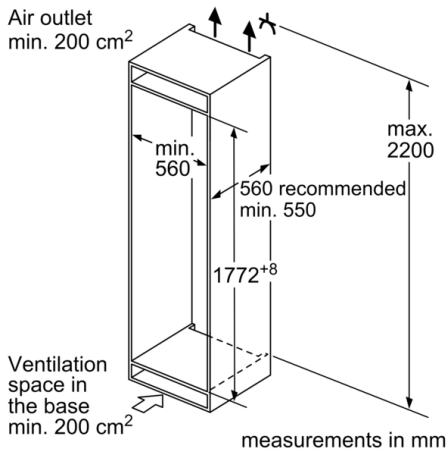
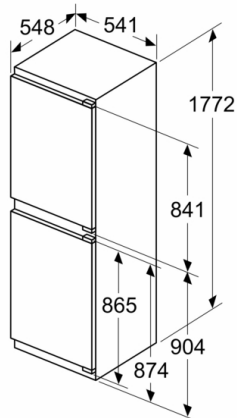

measurements in mm

Recommended gap dimensions for flat hinges

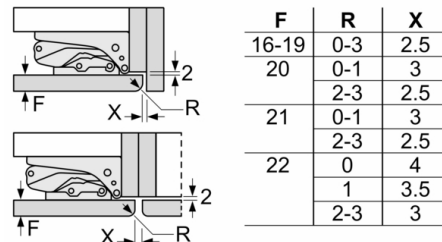

The gap dimensions recommended in the table must be adhered to in order to ensure that appliance doors do not collide with anything when they are opened, and to avoid causing damage to kitchen units.

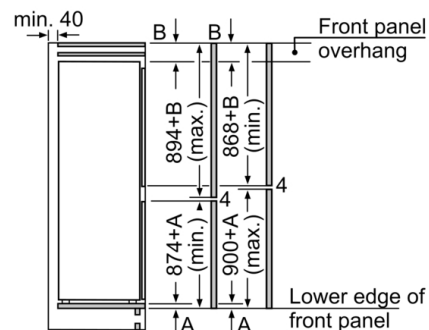

The specified unit door dimensions are valid for a door gap of 4 mm.

measurements in mm

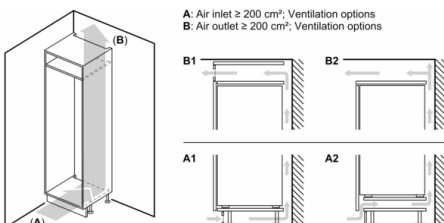

Maximal permissible weight of the unit fronts

Fitted unit fronts that exceed the permissible weight may cause damage and result in functional impairment of the hinges

Δ Weight

A: Appliance door height including hinges in mm

B: Undamped hinge, unit front in kg

C: Damped hinge, unit front in kg

D: Additional possible load in kg with heavy load kit

A	B	C	D
1500-1750	22	22	
720-1400	19	19	B+5 / C+5
A1	15	19	
A2	15	19	