

Series 4, Free-standing fridge-freezer with freezer at bottom, 203 x 70 cm, Stainless steel look KGN492LDFG

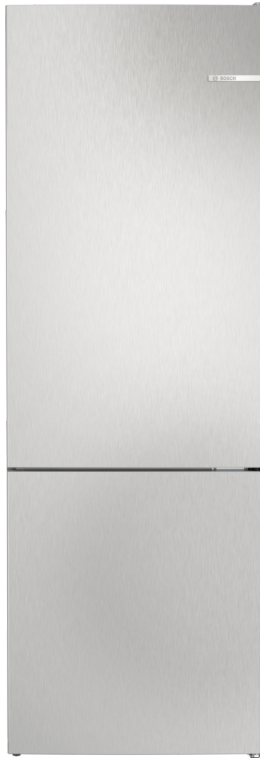

NoFrost bottomfreezer : no need to defrost your freezer

- **VitaFresh XXL Pro near 0°C:** climate-controlled compartments lock in freshness and nutrients for longer.
- **Glossy Backwall with Multi Airflow:** evenly circulates cool, fresh air to maintain consistent temperatures.
- **Perfect Fit:** place your fridge right next to walls or other appliances to save space.
- **LED lighting:** all your items in perfect view.
- **Two cooling systems:** separately controllable fridge and freezer compartments

Technical Data

Energy Efficiency Class:	D
Average annual energy consumption in kilowatt hour per year (kWh/a):	223 kWh/annum
Sum of volume of frozen compartments:	129 l
Sum of volume of chill compartments:	311 l
Airborne acoustical noise emissions :	35 dB(A) re 1 pW
Airborne acoustical noise emission class:	B
Built-in / Free-standing:	Freestanding
Door panel options:	Not possible
Height:	2030 mm
Width of the appliance:	700 mm
Depth:	667 mm
Net weight:	80.3 kg
Fuse protection:	13 A
Door hinge:	Right reversible
Voltage:	220-240 V
Frequency:	50 Hz
Length electrical supply cord:	231.0 cm
Number of compressors:	1
Number of independent cooling systems:	2
Interior ventilator:	No
Reversible Door Hinge:	Yes
Number of Adjustable Shelves in fridge compartment:	3
Shelves for Bottles:	Yes
Frost free system:	Fridge and freezer
Installation typology:	Free-standing



Series 4, Free-standing fridge-freezer with freezer at bottom, 203 x 70 cm, Stainless steel look KGN492LDFG

NoFrost bottomfreezer : no need to defrost your freezer

- Twin No Frost (RC + FC), Fridge freezer
- Standard door Stainless steel look

Performance and Consumption

- EU19_EEK_D: D
- Total Volume : 440 l
- Net Fridge Volume : 311 l
- Net Freezer Volume : 129 l
- Freezing capacity 24h : 11 kg
- Annual Energy Consumption: 223 kWh/a
- Climate Class: SN-T
- EU19_Fast freezer facility_D
- Noise Level : 35 dB , EU19_Noise emission class_D: B
- Temperature rise time : EU19_Temperature rise time_D: 18 H

Functions

- White glossy back wall
- Stainless steel look doors and Pearl grey (VZF 07127) side panels
- Integrated vertical handle
- Bright interior LED fridge light in fridge section

Design features

- NO_FROST_NEU_BL, never have to defrost ever again
- Separate, electronic temperature control with LED display
- Two separate cooling circuits allow independent temperature control and prevents the transference of humidity between the fridge and freezer cavity
- Super Cooling: automatic deactivation
- Optical and accoustical
- Freezer malfunction warning signal: optical and accoustical warning system

Design features

- MultiAirflow system - improves circulation of air around the fridge
- 5 safety glass shelves of which 3 are height adjustable
- Metal bottle rack
- Door shelves in fridge door: 1 large and 3 small.

Freshness System

- 1 VitaFresh drawer - Fish and meat stay fresh for longer
- 1 VitaFresh drawer with humidity control - Fruits and vegetables retain vitamins and stay fresh for longer

Food freshness system

- Net freezer capacity: 127 litres
- Freezing capacity in 24 hours: 9.5 kg
- Maximum freezer storage time in power failure: 18 hours
- 3 freezer drawers

Dimension and installation

- Dimensions: 203 cm H x 70 cm W x 66.7 cm D

Key features - Fridge section

- Right hinged door, door reversible
- Height adjustable front feet
- 220 - 240 V
- Length of power cord:231 cm

Key features - Freezer section

- 3 x egg tray, 1 x ice cube tray

Country Specific Options

- Based on the results of the standard 24-hour test. Actual consumption depends on usage/position of the appliance.

Design features

Dimension and installation

Additional features

**Series 4, Free-standing fridge-freezer
with freezer at bottom, 203 x 70 cm,
Stainless steel look
KGN492LDFG**

Measurements in mm

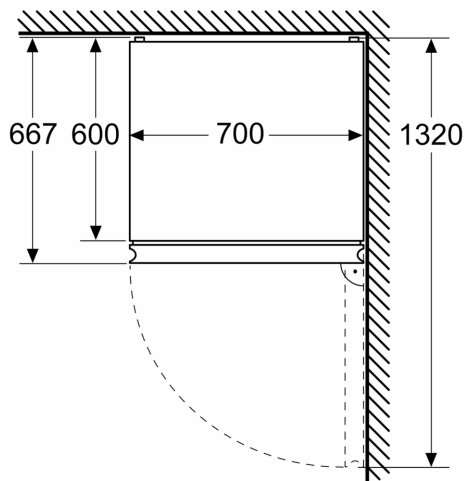

Measurements in mm

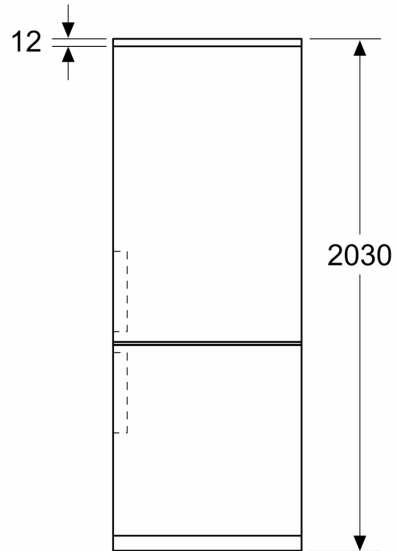

Measurements in mm

