

**iQ500, American side by side,
178.7 x 90.8 cm, Inox-easyclean
KA93IVIFPG**



Side by side fridge freezer with two Fresh Boxes for lots of fresh vegetables and fruits, plus noFrost for no more defrosting. Plus the handy addition of a 4.5l water tank for dispensing ice and water.

- ✓ noFrost – Never defrost your freezer again.
- ✓ Plenty of space for weekly shopping thanks to extra high capacity.
- ✓ superCooling: faster cooling for fresh food.
- ✓ superFreezing: fast freezing for even large quantities of food.
- ✓ varioZone – easily arrange drawers and glass shelves to bring flexibility to your freezer space.

Features

Technical Data

| | |
|--|--------------------|
| Energy Efficiency Class: | F |
| Average annual energy consumption in kilowatt hour per year (kWh/a): | 404 kWh/annum |
| Sum of volume of frozen compartments: | 191 l |
| Sum of volume of chill compartments: | 371 l |
| Airborne acoustical noise emissions : | 42 dB(A) re 1 pW |
| Airborne acoustical noise emission class: | D |
| Built-in / Free-standing: | Freestanding |
| Door panel options: | Not possible |
| Height: | 1787 mm |
| Width of the appliance: | 908 mm |
| Dimensions: | 707 mm |
| Weight: | 110.2 kg |
| Connection Rating: | 240 W |
| Fuse protection: | 13 A |
| Door opening: | left and right |
| Nominal power: | 220-240 V |
| Frequency: | 50 Hz |
| Length electrical supply cord: | 200.0 cm |
| Number of compressors: | 1 |
| Number of independent cooling systems: | 1 |
| Interior ventilator: | No |
| Reversible Door Hinge: | No |
| Number of Adjustable Shelves in fridge compartment: | 0 |
| Shelves for Bottles: | No |
| Capacity of Water Tank: | 4.5 l |
| EAN code: | 4242003866962 |
| Brand: | Siemens |
| Product name / Commercial code: | KA93IVIFPG |
| Frost free system: | Fridge and freezer |
| Installation type: | not available |
| Included accessories: | 1 x egg tray |



iQ500, American side by side, 178.7 x 90.8 cm, Inox-easyclean KA93IVIFPG

Features

Functions

- Stainless steel anti-fingerprint doors and grey side panels
- Brushed aluminium vertical door handle
- Bright interior LED fridge light

Design features

- NO_FROST_NEU_BL, never have to defrost ever again
- Indoor touch control electronics with digital display
- LED display for fridge and freezer
- Separate temperature control for cooling and freezing section
- Super Cooling: automatic deactivation
- superFreeze function with automatic deactivation
- Optical and acoustical door open warning system

Ice and Water

- Automatic ice cube maker

Design features

- multiAirflow cooling - improves circulation of air around the fridge
- 5 safety glass shelves
- 2 removable door storage compartments.

Freshness System

- 2 HyperFresh vegetable container on rails

Food freshness system

- 2 freezer drawers
- 3 door trays in the freezing compartment

Key features - Fridge section

- 4 height adjustable feet

Dimension and installation

- Dimensions: 178.7 cm H x 90.8 cm W x 70.7 cm D
- Connection value 240 W
- 220 - 240 V

Key features - Freezer section

- 3 x egg tray

Included accessories

Country Specific Options

- Based on the results of the standard 24-hour test. Actual consumption depends on usage/position of the appliance.

Design features

Dimension and installation

Additional features

Performance and Consumption

- EU19_EEK_D: F
- Total Volume : 562 l
- Net Fridge Volume : 371 l
- Net Freezer Volume : 191 l
- Freezing capacity 24h : 11 kg

- Annual Energy Consumption: 404 kWh/a
- Climate Class: SN-T
- Noise Level : 42 dB , EU19_Noise emission class_D: D

**iQ500, American side by side,
178.7 x 90.8 cm, Inox-easyclean
KA93IVIFPG**

Dimensioned drawings

Measurements in mm

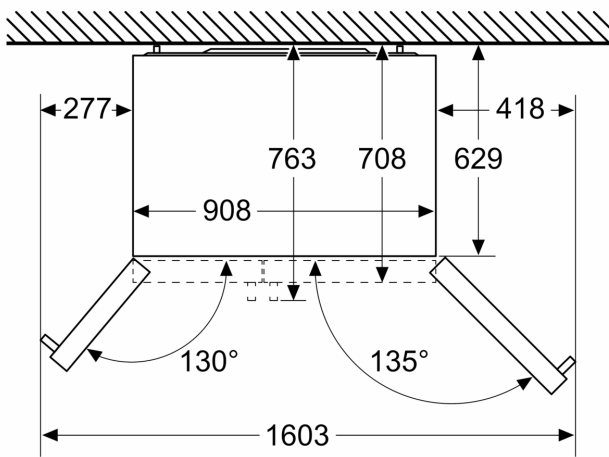

Measurements in mm

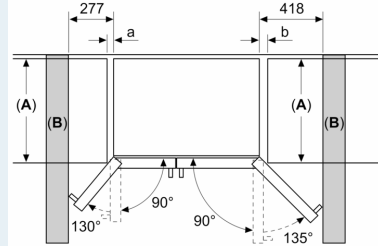

| A | a | b |
|---------------|-----|-----|
| ≤ 600 | 50 | 50 |
| 600 < A ≤ 650 | 50 | 50 |
| 650 < A ≤ 700 | 53 | 96 |
| > 700 | 277 | 418 |

A: Kitchen cabinet or worktop depth

B: Wall
Drawers can be pulled out with door open to 90°

Drawers can be taken out with door completely opened

measurements in mm

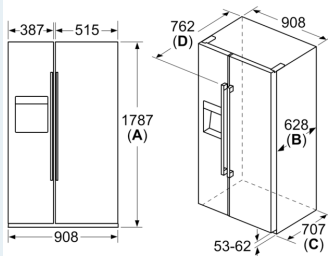

| Specifications |
|--|
| A Front is adjustable from 1783 to 1792 |
| B Cabinet depth |
| C Depth incl. door, without handle |
| D Depth incl. door, with handle |