

N 50, BUILT-UNDER DOUBLE OVEN J1ACE4HN0B

A

Built under double oven - twice as flexible, twice as fast - bake or roast multiple dishes at the same time.

- ✓ Eco Clean with Easy Clean - the duo that makes oven cleaning easier
- ✓ LCD-Display - simple, straightforward with large characters for clear reading
- ✓ Cliprails - Place dishes exactly where you want them in your oven.

Features

Technical Data

Construction type: Built-in
 Integrated Cleaning system: No
 Dimensions: 717 x 594 x 550 mm
 Dimensions of the packed product (HxWxD): . 790 x 690 x 660 mm
 Control Panel Material: Glass
 Door Material: Glass
 Net weight: 47.4 kg
 Usable volume of cavity: 47 l
 Cooking method: Full width grill, Hotair gentle, Hot Air, Conventional heat, Pizza setting, Bottom heat, Hot air grilling
 Oven control: mechanical
 Number of interior lights: 1
 EAN code: 4242004222002
 Energy efficiency rating: A
 Energy consumption per cycle conventional (2010/30/EC): 0.84 kWh/cycle
 Energy consumption per cycle forced air convection (2010/30/EC): 0.71 kWh/cycle
 Energy efficiency class (2010/30/EC) - cavity 2: B
 Energy consumption per cycle conventional - cavity 2 (2010/30/EC): 0.83 kWh/cycle
 Energy efficiency index (2010/30/EC): 94.7 %
 Energy efficiency index cavity 2 (2010/30/EC): 120.3 %
 Connection rating: 5300 W
 Fuse protection: 25 A
 Voltage: 220-240 V
 Frequency: 50 Hz
 Plug type: no plug (electrical connection by electrician), fixed connection
 Included accessories: 2 x combination grid, 1 x universal pan

Optional accessories

Z11AB15A0	Baking tray, non-stick ceramic coated
Z11AU15A0	Universal pan, non-stick ceramic coated
Z11CB10E0	Baking tray, grey enamelled
Z11CR10X0	Baking and roasting grid (standard)
Z11CU10E0	Multipurpose pan, grey enamelled
Z11GT10X3	Glass roasting dish, 5,4l
Z11TI15X0	Cliprails
Z1352X0	Pizza pan, grey enamelled
Z13CR10X0	Baking and roasting grid (steam)



N 50, BUILT-UNDER DOUBLE OVEN J1ACE4HNOB

Features

- LCD Display (White)

Features

- Control panel lock
- Interior halogen light
- Cavity volume: 34 Litre
- Cavity (inner surface) top: Enamel grey
- EcoClean Direct :ceiling, back panel, side liners
- Door hinge small cavity: bottom
- 1 Clip rail, Stop function
- Cavity (inner surface) bottom: enamel grey
- EasyClean
- Full glass inner door
- Door hinge big cavity: Drop down door

Top oven additional features

- Oven with 4 heating methods: Top/bottom heat, Full surface grill, Small area grill, Bottom heat
- Temperature range 50 °C - 275 °C

Main oven additional features

- 2 x combination grid, 1 x universal pan

Performance/technical information

- Nominal voltage: 220 - 240 V
- Appliance dimension (hxxxd): 717 mm x 594 mm x 550 mm
- Please refer to the dimensions provided in the installation manual

N 50, BUILT-UNDER DOUBLE OVEN
J1ACE4HNOB

Dimensioned drawings

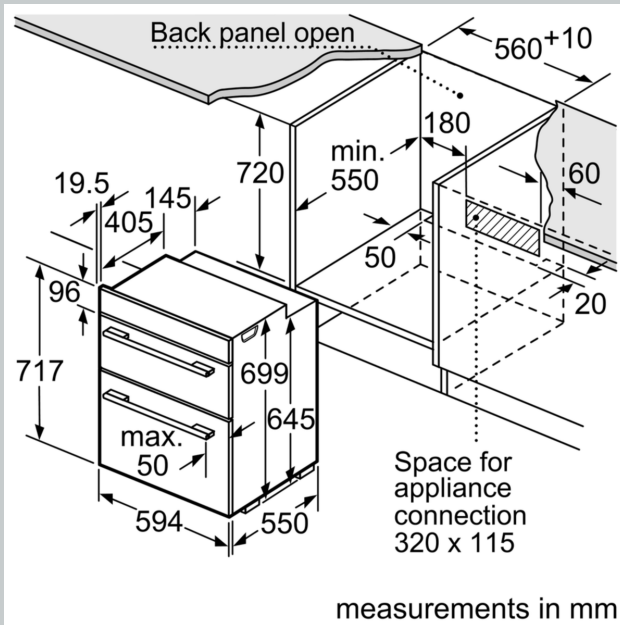

measurements in mm

If the appliance will be installed underneath a hob, the following worktop thicknesses (including substructure if necessary) must be taken into account.

Hob type	min. worktop thickness	
	fitted	flush
Induction hob	39	40
Full-surface induction hob	49	50
Gas hob	29	40
Electric hob	29	32

measurements in mm
Installation with a hob

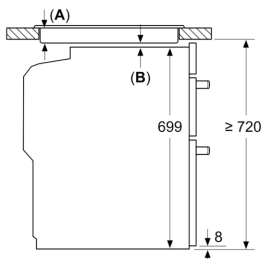

- A: Recessed depth 29-50 mm.
See hob dimensional drawing.
- B: Min. distance:
Induction hob: 5 mm
Gas hob: 5 mm
Electric hob: 2 mm

measurements in mm

