

*N 70, BUILT-IN COMPACT OVEN WITH  
MICROWAVE FUNCTION, 60 X 45 CM, STAINLESS  
STEEL  
C24MR21NOB*

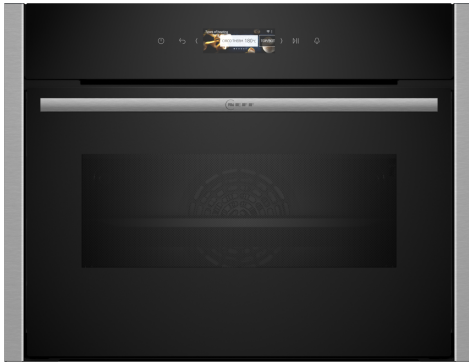

#### Included accessories

1 x combination grid, 1 x universal pan

#### Optional accessories

Z12CU10A0 Multipurpose pan, anthracite enamelled, Z13CR10X0 Baking and roasting grid (steam), Z13CV05S0 Cover Strip, Z13CV06S0 Decor strip, Z1650BE0 Half tray, Z1655CA0 Air Fry & Grill tray, anthracite, Z1913X0 Baking Stone, Z19DD10X0 Steam set for ovens, Z11AB15A0 Baking tray, non-stick ceramic coated, Z11AU15A0 Universal pan, non-stick ceramic coated, Z11CR10X0 Baking and roasting grid (standard), Z11GT10X3 Glass roasting dish, 5,4l, Z11GU20X0 Glasspan, Z11SZ00X0 SeamlessCombination mounting kit, Z11SZ60X0 SeamlessCombination 45 + 14cm, Z11SZ90X0 SeamlessCombination 60 + 45cm, Z12CB10A0 Baking tray, anthracite enamelled, Z12CM10A0 Moussaka pan, anthracite enamelled, Z12CP10A0 Pizza pan, anthracite enamelled

Compact built-in oven with microwave - to cook quickly and conveniently in a very small space. Home Connect for control via the App.

- ✓ 3,7" Full Touch TFT Display - Intuitive navigation for easy use and complete control.
- ✓ Inverter Technology - Heat food gradually and evenly.
- ✓ Combined microwave and oven - the convenient solution to save space and time
- ✓ Circo Therm® - Even heat distribution for perfect results on one level.
- ✓ Easy Clean - this special cleaning aid provides fast, uncomplicated, energy-saving cleaning of the oven interior.

#### Features

##### Technical Data

Type of micro-wave oven: ..... MW-Combi  
 Type of control: ..... Electronic  
 Color / Material Front: ..... Stainless steel  
 Dimensions: ..... 455 x 596 x 548 mm  
 Cavity dimensions: ..... 237.0 x 480 x 392.0 mm  
 Length of electrical supply cord: ..... 150.0 cm  
 Net weight: ..... 32.8 kg  
 Gross weight: ..... 35.1 kg  
 EAN code: ..... 4242004270386  
 Maximum micro-wave power: ..... 900 W  
 Connection rating: ..... 3600 W  
 Fuse protection: ..... 16 A  
 Voltage: ..... 220-240 V  
 Plug type: ..... no plug  
 (electrical connection by electrician)  
 Included accessories: ..... 1 x combination grid, 1 x universal pan



*N 70, BUILT-IN COMPACT OVEN WITH  
MICROWAVE FUNCTION, 60 X 45 CM, STAINLESS  
STEEL  
C24MR21NOB*

#### Features

- Compact oven with microwave with 16 heating methods: Top/bottom heat, Circo-roasting, Full surface grill, Centre surface grill, Bottom heat, Dough proving, Plate warming, CircoTherm® gentle, Conventional heat gentle, Circulating air, Microwave, Circulating air, Conventional heat, Full width grill, Half width grill, Hot air grilling
- Intelligent microwave inverter technology: For optimised results maximum output power will be regulated to 600 W when used in longer operation for gentler cooking.
- Please refer to the dimensions provided in the installation manual

#### Design

- Touch control
- Cavity inner surface: enamel anthracite

#### Features

- HomeConnect ready on WLAN
- Oven Assistant with Voice Control
- Control panel lock
- Automatic safety switch off Residual heat indicator Start button Door contact switch

#### Programmes/functions

- Temperature range 30 °C - 230 °C
- Max. Power: 900 W; 5 Microwave power settings (90 W, 180 W, 360 W, 600 W, boost) with Inverter (MW)
- LED light, On/off button
- Electronic clock timer
- Drop down door, SoftClose, soft opening
- Heat reflective glass
- Triple glazed door glazed CoolTouch door
- Temperature proposal
- Actual temperature display Heating up indicator
- cookControl Plus
- No
- Cooling fan
- Stainless-steel fan

#### Level independent telescopic rails

- 3 shelf positions

#### Cleaning

- EasyClean

#### Accessories

- 1 x combination grid, 1 x universal pan

#### Performance/technical information

- Power cord length 150 cm Cable length
- Nominal voltage: 220 - 240 V
- Total connected load electric: 3.6 KW
- Cavity volume: 45 litre
- Appliance dimension (hxwxh): 455 mm x 596 mm x 548 mm
- Niche dimension (hxwxh): 450 mm - 455 mm x 560 mm - 568 mm x 550 mm

N 70, BUILT-IN COMPACT OVEN WITH  
MICROWAVE FUNCTION, 60 X 45 CM, STAINLESS  
STEEL  
C24MR21NOB

## Dimensioned drawings

Installing two appliances on top of each other  
Air exchange

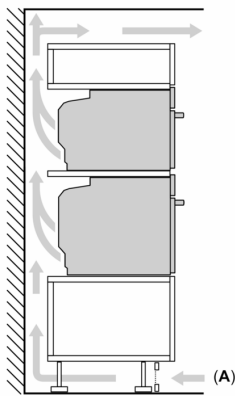

A: Air inlet  $\geq 200 \text{ cm}^2$

Measurements in mm

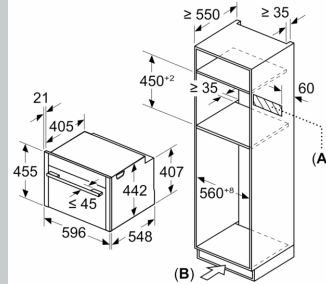

A: Space for appliance connection  
 $320 \times 115 \text{ mm}$

B: Ventilation space in the base  $\geq 200 \text{ cm}^2$

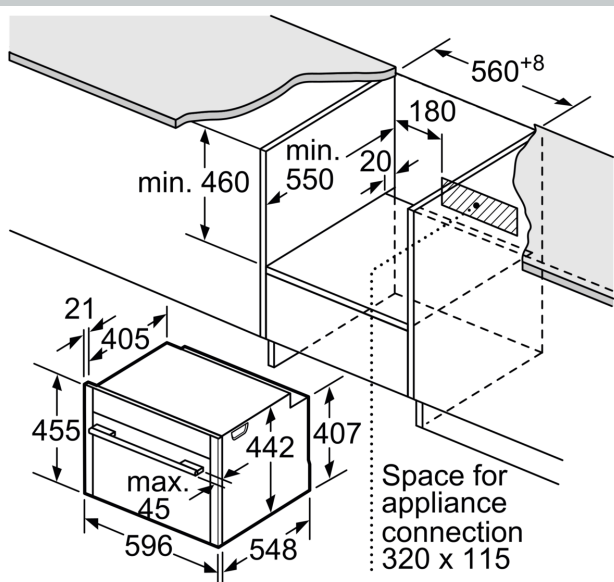

measurements in mm

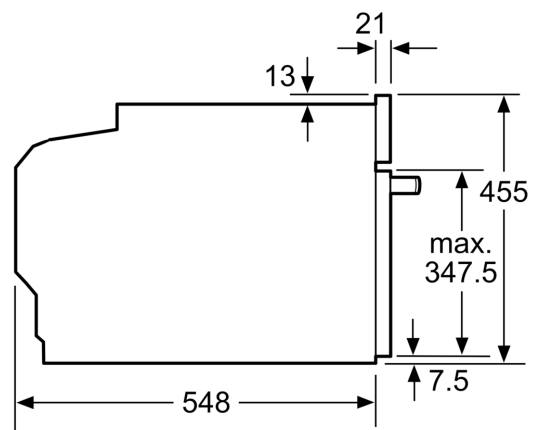

measurements in mm

## Dimensioned drawings

## Installation with a hob.

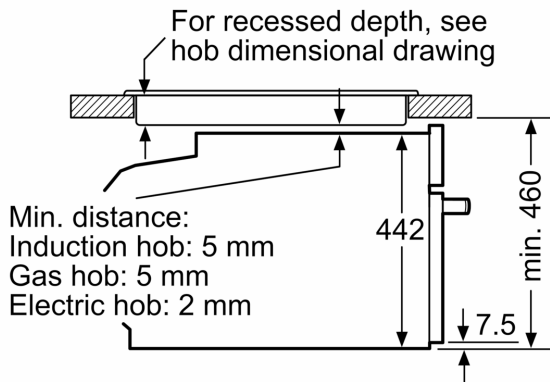

measurements in mm

If the compact appliance will be installed underneath a hob, the following worktop thicknesses (including substructure if necessary) must be taken into account.

Hob type	min. worktop thickness	
	fitted	flush
Induction hob	42 mm	43 mm
Full surface Induction hob	52 mm	53 mm
Gas hob	32 mm	43 mm
Electric hob	32 mm	35 mm