

# Integrated French Door Refrigerator Freezer, 90cm

Series 7 | Integrated

Panel Ready | French hinge



This large capacity refrigerator with bottom freezer seamlessly integrates into your kitchen, fitting flush into your cabinetry.

- ActiveSmart™ technology helps keep food fresher for longer by constantly maintaining the ideal temperature.
- Customise with your own kitchen cabinetry or purchase our stainless steel door panel accessory
- Spacious bottom freezer with full extension drawer gives easy access to frozen goods.

## DIMENSIONS

Height	1798mm
Width	896mm
Depth	610mm

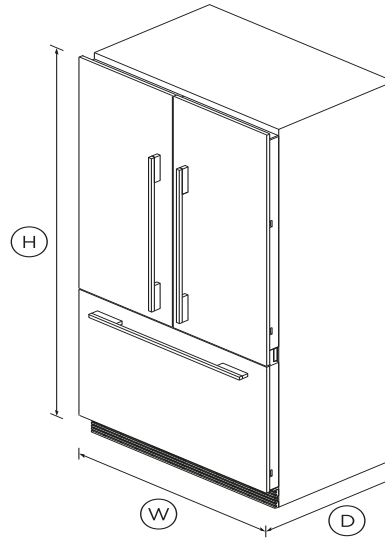

## FEATURES & BENEFITS

### ACTIVESMART™ FOODCARE

ActiveSmart™ Foodcare learns how you live. It is technology which understands how you use your refrigerator and adjusts temperature, airflow and humidity inside to help keep food fresher for longer.

### SIMPLE STORAGE

This refrigerator is designed to make it simple for you to store, access and remove food. Storage bins give you full access inside when they're pulled open and can be easily removed to clean.

Our flexible shelving also gives you more storage options.

### CLEVER ENERGY

Your refrigerator adapts to daily use by cooling and defrosting only when needed. This ActiveSmart™ technology means better energy efficiency without compromising on food care.

### EASY CLEANING

Spill-safe secure glass shelves easily capture any drips or leaks and prevent them from falling on items below.

### EASY INSTALLATION

Our integrated products are easy to install, whether you are renovating your kitchen or designing a new one. Adjustable front and rear feet allow for uneven floors alongside adjustable door panels that can be customised to match your kitchen.

### DESIGN QUALITY

Our refrigerators are designed and built using quality materials. We use real stainless steel, and solid glass for shelving.

## SPECIFICATIONS

### Accessories (sold separately)

Door panel stainless steel	RD90A
Handle kit Contemporary	AHS-ASBI-A
Handle kit Contemporary	AHD5RD90A
Handle kit Contemporary	AHD5RD90AB
Handle kit Contemporary	RS90A

### Capacity

Volume freezer	145L
Volume refrigerator	331L

### Consumption

Energy consumption	332kWh/year
--------------------	-------------

Energy rating	<b>F</b>
Energy usage	<b>332kWh/year</b>

**Features**

Adjustable door shelves	<b>6</b>
Adjustable glass cantilevered	•
Adjustable glass shelves	<b>3</b>
Covered door shelves	<b>2</b>
Door alarm	•
Fruit and vegetable bins	<b>2</b>
Gallon door shelves	<b>1</b>
LED lighting	•
SmartTouch control panel	•
Soft close doors	•
Spill proof removable bins	•
Stackable bottle holders	<b>4</b>

**Freezer Features**

Bottle chill	•
Door alarm	•
Fast freeze	•
Ice trays	<b>1</b>
LED lighting	•
Large plastic bins	•
Slide Out Pastry Tray	•
Small plastic bins	•

**Performance**

ActiveSmart™ Foodcare	•
Adaptive defrost	•

Frost free freezer	•
Humidity control system	•
Inverter controlled compressor	•
Noise emissions	<b>42dBA</b>
Noise emissions class	<b>D</b>
Sabbath mode	•

**Power requirements**

Supply voltage	<b>230V</b>
----------------	-------------

**Product dimensions**

Depth	<b>610mm</b>
Height	<b>1798mm</b>
Width	<b>896mm</b>

**Warranty**

Parts and labour	<b>5 years</b>
Sealed system parts only	<b>5 years</b>

SKU	<b>26524</b>
-----	--------------

The product dimensions and specifications in this page apply to the specific product and model. Under our policy of continuous improvement, these dimensions and specifications may change at any time. You should therefore check with Fisher & Paykel's Customer Care Centre to ensure this page correctly describes the model currently available. ? Fisher & Paykel Appliances Ltd 2020

**Other product downloads available at fisherpaykel.com**

- [↓](#) Service & Warranty
- [↓](#) User Guide Integrated Refrigerator Freezer
- [↓](#) Declaration of Conformity
- [↓](#) User Guide Integrated Refrigerator Freezer
- [↓](#) Declaration of Conformity Refrigeration with WiFi Capability
- [↓](#) Installation Guide Integrated French Door Refrigerator Freezer
- [↓](#) Data Sheet Integrated French Door Fridge Freezer
- [↓](#) Planning Guide Integrated French Door Fridge Freezer



**A PEACE OF MIND SALE**

**24 Hours 7 Days a Week Customer Support**

**T 08000 886 605 Wwww.fisherpaykel.com**